

PARAMAX[®] DRIVE

For Extruders SEC Series

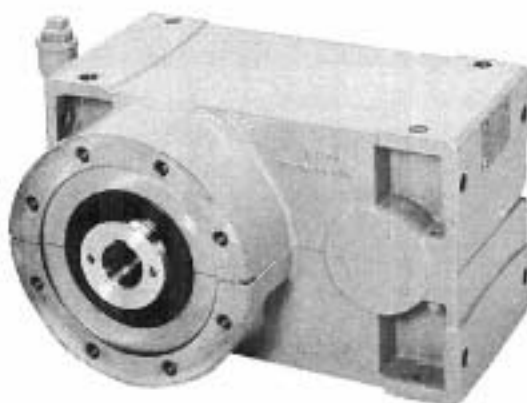

- PARAMAX DRIVE FOR EXTRUDERS should be handled, installed and maintained by trained technicians. Carefully read the maintenance manual before use.
- Oil is removed from PARAMAX DRIVE FOR EXTRUDERS before shipment. Supply oil according to the maintenance manual before operation.
- A copy of this maintenance manual should be sent to the actual user of PARAMAX DRIVE FOR EXTRUDERS.
- This maintenance manual should be maintained by the user.

(Safety and other precautions)

- Carefully read this maintenance manual and all accompanying documents before use (installation, operation, maintenance, inspection, etc.). Thoroughly understand the machine, information about safety, and all precautions for correct operation.
Maintain this manual for future reference.
- Pay particular attention to the "DANGER" and "CAUTION" warnings regarding safety and proper use.



DANGER

: Improper handling may result in physical damage, serious personal injury and/or death.



CAUTION

: Improper handling may result in physical damage and/or personal injury.

Matters described in  **CAUTION** may lead to serious danger depending on the situation. Be sure to observe important matters described herein.

DANGER

- Transport, installation, plumbing, operation, maintenance, and inspections should be handled by properly trained technicians ; otherwise, injury or damage to the machine may result.
- Do not disassemble PARAMAX DRIVE FOR EXTRUDERS during operation. Even if it is at rest, do not disassemble any parts other than the oil inlet/outlet when the input/output shafts of the PARAMAX DRIVE FOR EXTRUDERS is connected to a motor or other mating machines; otherwise falling or operation out of control due to disengagement of gears, as well as death, injury, or damage to the machine may result.

CAUTION

- The unit should be operated only within its design and performance specifications ; otherwise, injury or damage to a system may occur.
- Keep hands and all foreign objects from the internal moving parts of the unit ; otherwise, injury or damage to a system may occur.
- Damaged units should be taken off - line and not put back in operation until properly repaired.
- Any modifications or alterations of any kind, to the unit, will void the warranty and all subsequent claims.
- Do not remove the rating plate.

- Oil has been removed from PARAMAX DRIVE FOR EXTRUDERS before shipment from our factory, so supply recommended oil before use.

CONTENTS

Safety and other precautions.....	1	7. Operation	7
1. Inspection upon delivery	2	8. Daily inspection and maintenance	8
2. Storage.....	4	9. Troubleshooting	10
3. Transport.....	4	10. Disassembly/reassembly and disposal	10
4. Installation	4	11. Construction drawing	11
5. Coupling with other machines	5	12. Locations of oil filler and drain plug.....	13
6. Lubrication.....	6	13. Warranty.....	14

1. Inspection upon delivery

⚠ CAUTION

- Unpack the unit after verifying that it is positioned right side up ; otherwise, injury may result.
- Verify that the unit received is in fact the one ordered. When a different product is installed, injury or damage to the system may result.
- Do not remove nameplate.

Upon delivery of the PARAMAX DRIVE FOR EXTRUDERS, check the following :

- (1) The descriptions on the rating plate conform to your order.
- (2) There were no parts damaged during transport.
- (3) All bolts and nuts are firmly tightened.

If there is any doubt that the unit delivered does not conform to the one ordered, contact the nearest agent, distributor or service office.

1 — 1) How to check the rating plate

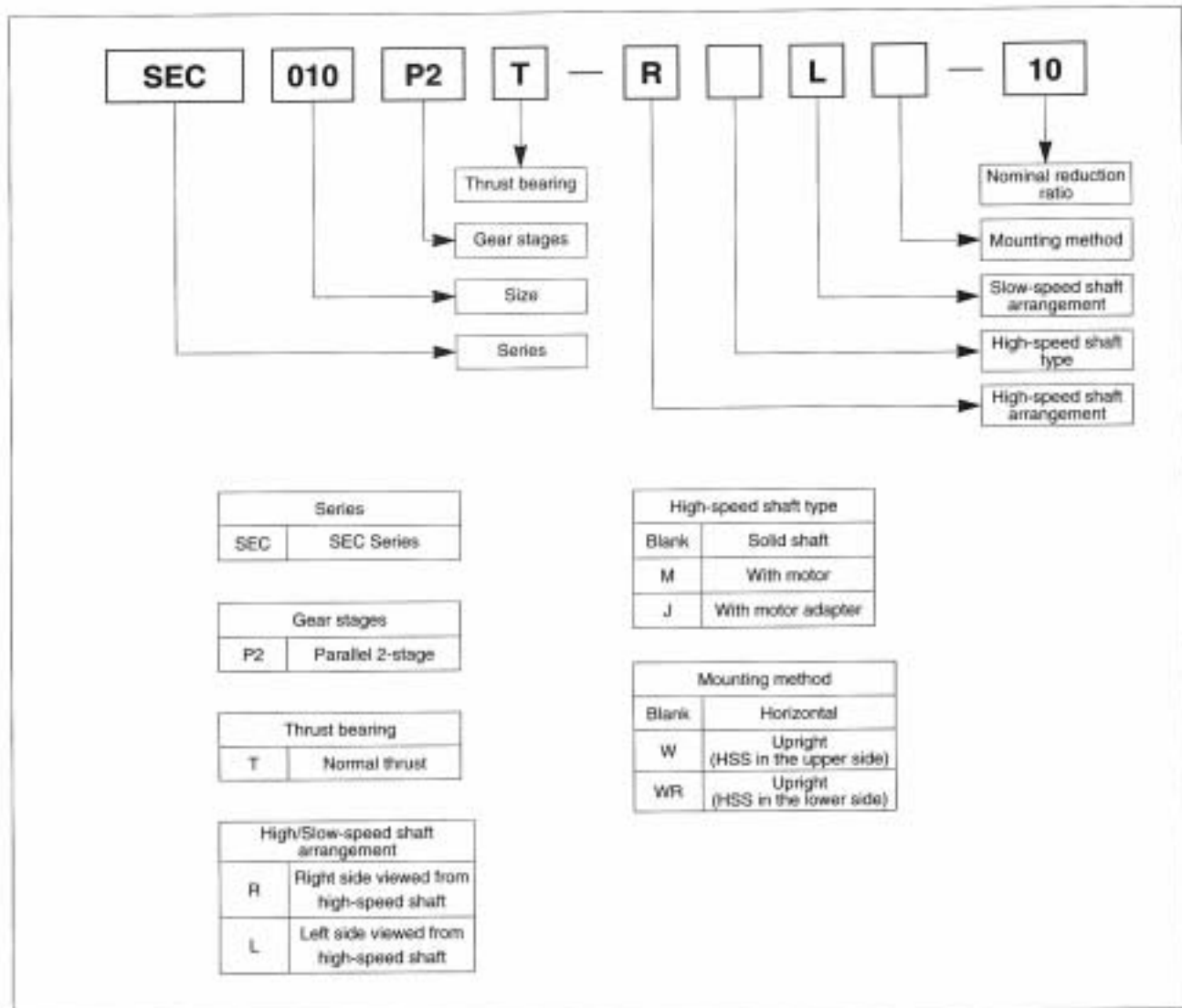

Fig. 1 Rating plate

• Have the ①MODEL ②RATIO ③SERIAL No. information ready when making inquiries.

1 — 2) Types of reducers

Symbols denote the following. Check that the type of reducer conforms to your order.



2. Storage

When storing PARAMAX DRIVE FOR EXTRUDERS for any extended periods of time before use, consider the following important points.

2 — 1) Temporary storage

- (1) Store PARAMAX DRIVE FOR EXTRUDERS in a clean, dry, covered storage area.

- Do not store PARAMAX DRIVE FOR EXTRUDERS outdoors or in a wet location.

2 — 2) Long-term storage

- (1) The oil seal will deteriorate when exposed to high temperatures and UV rays. Inspect and replace the oil seal after long-term storage if there are any signs of damage or cracking.
- (2) After starting PARAMAX DRIVE FOR EXTRUDERS, check that it is free from abnormal sound, vibration, or heat build-up. (If any kind of anomaly is observed) contact the nearest agent, dealer, or service office immediately.
- (3) Every 2 — 3 months after shipment, operate PARAMAX DRIVE FOR EXTRUDERS with the recommended lubricant for 5 — 10 minutes. If this is not possible, or when PARAMAX DRIVE FOR EXTRUDERS is to be stored for more than 6 months, fill the unit with the proper amount of vapor phase inhibitor (JIS NP20 or its equivalent) according to the inhibitor manufacturers recommendations.

3. Transport

⚠ DANGER

- Never stand directly under a unit suspended by a crane or other lifting mechanism ; otherwise personal injury or death may result.

⚠ CAUTION

- Exercise ample care not to drop PARAMAX DRIVE FOR EXTRUDERS during transport. When a hanging bolt or hole is provided, be sure to use it. After mounting PARAMAX DRIVE FOR EXTRUDERS on a system, however, do not hoist the entire system using the hanging bolt or hole. Otherwise, personal injury or damage to the equipment and/or lifting device may result.
- Before hoisting, check the weight with the rating plate, crate, performance specifications, catalog, etc. Never hoist a PARAMAX DRIVE FOR EXTRUDERS that exceeds the rating of the crane or other mechanism being used to lift it ; otherwise, injury or damage to the unit and/or lifting device may occur.

4. Installation

⚠ CAUTION

- Do not place any objects that will hinder ventilation around PARAMAX DRIVE FOR EXTRUDERS; otherwise, cooling effect is reduced, and may lead to a possible fire hazard due to excessive heat build-up.
- Do not step on or hang from PARAMAX DRIVE FOR EXTRUDERS; otherwise, injury or damage to the machine may result.
- Do not touch the key way at the shaft end or on the inside of PARAMAX DRIVE FOR EXTRUDERS; otherwise, injury may result.
- When PARAMAX DRIVE FOR EXTRUDERS is used in food processing applications vulnerable to oil contamination, install an oil pan or other such device to cope with oil leakage due to failure or limited service life. Otherwise, oil leakage may damage products.
- Do not use PARAMAX DRIVE FOR EXTRUDERS for purposes other than those shown on the rating plate or in the manufacturing specifications; otherwise, electric shock, personal injury or damage to the equipment may result.
- Do not place flammable objects around PARAMAX DRIVE FOR EXTRUDERS; otherwise, fire may result.

4 — 1) Location of installation

Ambient temperature : -10 to +40°C

Ambient humidity : 85% max.

Ambient atmosphere : There shall be no corrosive gas, explosive gas, or steam.

The installation space shall be well ventilated, and free from dust.

Location of installation : Indoors, with minimum dust and no water splashing.

- Special specifications are necessary when installation conditions are other than those mentioned here. In such cases contact the nearest agent, dealer or service office.
- When a product is made according to special specifications for outdoor use or use in explosive environments, the product can be safely operated under those specified conditions without problem.
- Install PARAMAX DRIVE FOR EXTRUDERS on a sufficiently rigid base.
- Install PARAMAX DRIVE FOR EXTRUDERS where inspection, maintenance, and other such operations can be easily carried out.

4 — 2) Installation angle

When PARAMAX DRIVE FOR EXTRUDERS is made according to your specification for inclined installation, do not install it at any angle other than the specified angle.

- Use installation bolts corresponding to JIS strength class 10.9 or its equivalent.

5. Coupling with other machines

CAUTION

- Install appropriate guard devices around rotating parts ; otherwise, injury may result.
- When coupling PARAMAX DRIVE FOR EXTRUDERS with a load, confirm that the alignment error is within the specified limits shown in the maintenance manual, drawings, catalog, etc. ; otherwise, damage to the system may result, due to misalignment.
- Correctly tighten respective bolts to the specified torque shown in the drawing, catalog, etc. ; otherwise ; scattering fragments may damage the system.
- When a belt is used for coupling the unit with another machine, check that the belt tension and the parallelism of the pulley are within the specified limits. When the unit is directly coupled with another machine, check that the direct coupling accuracy is within the specified limits ; otherwise, the system may be damaged, due to misalignment.
Do not change the pulley ratio assumed when purchasing PARAMAX DRIVE FOR EXTRUDERS.
When the pulley ratio is enlarged, the increase in torque may damage the system.
- Remove the key temporarily attached to the output shaft of PARAMAX DRIVE FOR EXTRUDERS when the shaft is free-rotating (i. e. not loaded) ; otherwise, injury may result.
- Confirm the direction of rotation before coupling PARAMAX DRIVE FOR EXTRUDERS with its driven machine. Difference in the direction of rotation may cause injury or damage to the system.

5 — 1) Installation coupler

- When attaching a coupler, be careful not to apply impact force or excessive thrust to the shaft ; otherwise, the bearing may be damaged.
- Shrink fit or shaft-end thread is recommended for mounting (Fig. 2)

(1) Use of coupling

The dimensions (A, B, and X) illustrated in Fig. 3 shall be within the tolerance shown in Table 1.

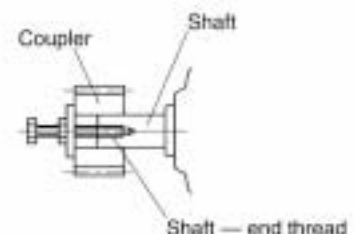

Fig. 2

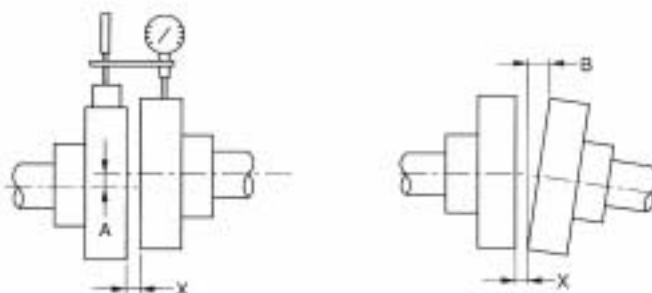

Fig. 3

Table 1 Aligning tolerance for coupling

Tolerance for A dimension	0.05mm
Tolerance for B dimension	0.05mm
X dimension	Specified by coupling manufacturer

(2) Use of chain, sprocket, and gear

- The chain tension angle shall be perpendicular to the shaft of PARAMAX DRIVE FOR EXTRUDERS.
- The pitch circle of the sprocket and gear shall be more than three times the shaft diameter.
- Locate the sprocket and gear as close to PARAMAX DRIVE FOR EXTRUDERS as possible so that the point of application of the load will be closer to the PARAMAX DRIVE FOR EXTRUDERS' S vertical centerline.

(3) Use of V belt

- Excessive V belt tension will damage the high speed shaft and bearing. The amount must be specified by V belt manufacturer.
- Pulleys must be parallel within 20' (arc) or less. (Fig. 4)
- Use a matched set with identical circumferential length when more than one V belt is used.

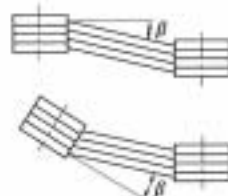

Fig. 4

6. Lubrication

6 — 1) Shipping condition

- PARAMAX DRIVE FOR EXTRUDERS units are shipped without oil. Supply recommended oil before operation.

6 — 2) Method of lubrication

The oil bath lubrication method is used for PARAMAX DRIVE FOR EXTRUDERS. An oil pump may be used for forced lubrication depending on operating conditions.

6 — 3) Forced lubrication

CAUTION

- For a system in which a lubricant motor pump is provided separately, switch on the pump motor prior to switching on the reducer motor. This will enable proper lubrication of the bearings prior to start – up. Failure to do so may damage the unit.

Use a flow switch and/or sight to verify that lubricant is circulating, and for emergency motor stop if necessary.

6 — 4) Selection of lubricant

Refer to Table 2 to select appropriate viscosity.
Table 3 shows recommended lubricants.

Table 2 Lubricant viscosity

	Ambient temperature		
	-10°C — +16°C	0°C — 30°C	10°C — 50°C
ISO* AGMA	VG100 3EP	VG220 5EP	VG320 6EP

*ISO : Kinetic viscosity (mm²/s) at 40°C

Table 3 Recommended lubricants

	Brand	ARAL	BP	CASTROL	CHEVRON	ELF	EXXONMOBIL	FINA	GULF	SHELL	SUNOCO	TEXACO	TOTAL	WINTER-SHALL	
Gear oil	ISO VG100 AGMA 3EP	DEGOL BG100	ENERGOL GR-XP-100	ALPHA SP100	NL GEAR COMPOUND 100	REDUCTELF SP 100	SPARTAN EP100	MOBIL- GEAR 627	GIRAN 100	EP LUBRICANT HD100	OMARA 100	SUNEP 1055 ISO100	MEROPA 100	CARTER EP100	WOLAN IT100
	ISO VG220 AGMA 5EP	DEGOL BG220	ENERGOL GR-XP-220	ALPHA SP220	NL GEAR COMPOUND 220	REDUCTELF SP 220	SPARTAN EP220	MOBIL- GEAR 630	GIRAN 220	EP LUBRICANT HD220	OMARA 220	SUNEP 1070 ISO220	MEROPA 220	CARTER EP220	WOLAN IT220
	ISO VG320 AGMA 6EP	DEGOL BG320	ENERGOL GR-XP-320	ALPHA SP320	NL GEAR COMPOUND 320	REDUCTELF SP 320	SPARTAN EP320	MOBIL- GEAR 632	GIRAN 320	EP LUBRICANT HD320	OMARA 320	SUNEP 1070 ISO320	MEROPA 320	CARTER EP320	WOLAN IT320

6 — 5) Oil quantity

An estimated quantity of oil for standard specifications is shown in Table 4. The oil quantity shown in Table 4 and the catalog is not exact. Use a dipstick or visible oil gauge to check the oil level.

Table 4 Approx. quantity of oil

(Unit : ℓ)

Size	005	010	020	030	040	060
H Mounting	3	3.5	5	7	12.5	25
W Mounting	4.5	5.5	7.5	11	19.5	39
WR Mounting	4.5	5.5	8	11.5	18.5	37

6 — 6) Oil supply

Supply oil through the filling port atop the main unit. Check the oil level with a visual oil gauge. (Fig. 5) Exercise care when supplying oil to ensure that loose nuts, bolts, washers, dust, water, and other foreign substances will not enter the unit. If will not be the oil level is lower than the specified range, lubrication sufficient. In case the oil level is higher, deterioration of oil is accelerated due to oil temperature rise.

The oil level shall be within this range.

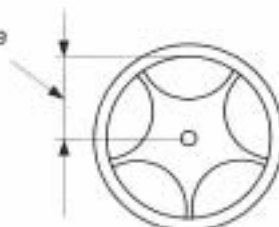

Fig. 5

6 — 7) Waste oil

Remove the drain plug under the main unit to drain waste oil while it is still warm. (i. e. Soon after operation of the unit has ceased. But not immediately after.)

7. Operation

⚠ DANGER

- Never approach or touch any rotating parts (shaft, etc.) during operation. Loose clothing caught in these rotating parts may result in severe injury and/or death.

⚠ CAUTION

- Do not put fingers or foreign objects into the opening of PARAMAX DRIVE FOR EXTRUDERS; otherwise, electric shock, personal injury, fire, or damage to the system may result.
- The reducer will get very hot during operation. Do not touch or come in contact in any way with the reducer ; otherwise, you may suffer burns.
- If the reducer is operating in an abnormal way, stop the unit immediately ; otherwise, electric shock, personal injury, or fire may result.
- Do not operate the reducer in a manner that exceeds its rating criteria ; otherwise, injury or damage to the system may result.
- Do not remove any covers or open the reducer during operation ; otherwise, splashing lubricant may cause burns.
- Do not loosen the oil filler plug during operation ; otherwise, splashing lubricant may cause burns.
- When reversing the direction of rotation, first bring the unit to a complete stop, then commence reverse rotation ; otherwise, the system may be damaged.

After installation, check the following points prior to operation.

(1) Is the reducer correctly coupled with the mating machine ?

(2) Are foundation bolts firmly tightened ?

(3) Does the direction of rotation conform to the one specified and designed for ?

After confirming the above, allow for a no-load break-in period. Then gradually apply the design load.

At this time, confirm the following :

Table 5

Items to be checked during break-in period/possible causes.	
Abnormal sound and vibration	(1) The housing is deformed because the installation surface is irregular. (2) Resonance is occurring due to the lack of rigidity of the installation base. (3) The shaft center is not properly aligned with the mating machine. (4) The vibration of the mating machine is transmitted to the reducer.
The surface temperature of the reducer is abnormally high.	(1) The motor current has exceeded the rated current shown in the rating plate. (2) The voltage rise and drop of the motor is too large. (3) The ambient temperature at which the reducer is operating is too high. (4) The oil is not at its specified level (too low or too high).

When an anomaly is found, stop operation, and contact the nearest agent, dealer, or service office.

8. Daily inspection and maintenance

DANGER

- Never approach or touch any rotating parts (shaft, etc.) when maintaining or inspecting the reducer during operation.
Loose clothing caught in these rotating parts may result in severe injury and/or death.
- Be sure to stop both the driving and driven machines before checking any tooth surfaces; otherwise, you may be caught in the gear engaging section, resulting in severe injury and/or death.
- Do not operate any units without all (safety) covers in place. Failure to do so may cause injury and/or death.

CAUTION

- The surface of the reducer will get hot, do not touch the reducer ; otherwise, a burn may result.
- Do not change the oil during operation or soon after operation has ceased ; otherwise, the hot oil may cause burns.
- Do not remove any covers or open the reducer during operation ; otherwise, splashing hot lubricant may cause burn.
- Change lubricant according to the maintenance manual, and use only those recommended lubricants ; otherwise, the system may be damaged.
- Promptly identify and correct, according to instructions in this maintenance manual, any abnormalities observed during operation. Do not operate until abnormality is corrected.
- Do not operate damaged PARAMAX DRIVE FOR EXTRUDERS; otherwise, injury, fire, or damage to the system may result.
- We cannot assume any responsibility for damage or injury resulting from an unauthorized modification by a customer.

- If following parts are exchanged after 3-5 year operation, although they are different from each of the usage conditions, longer operation life would be expected.

Exchange parts

- ◆ Bearing, oil seal, collar, key, stopper, visible gauge.
- ◆ In the case of forced lubrication
All the piping parts containing an electric pump or shaft driven pump.
Regarding special equipments, determine every time it is necessary.
- ◆ Check and exchange shaft and gear if there are damages.
- ◆ Regarding other parts, determine every time it is necessary.

In the case of PARAMAX DRIVE FOR EXTRUDER, if the unit is returned to the factory. Please inform manufacturing No., sales No., model, and quantity, etc.

8 — 1) Daily inspection

To ensure proper and continued optimum operation, use the table below to perform daily inspections of the unit.

Table 6

Inspection item	Details of inspection
Noise	Is there abnormal sound or sudden change in the noise characteristics during operation ?
Vibration	Is there any abnormal vibration or sudden change in the vibration of the reducer?
Surface temperature	Is the temperature of the surface of the reducer abnormally high ? Or is it rising rapidly? (The temperature rise during operation differs according to the type of reducers. A surface temperature of approx. 80°C will not cause any adverse effects as long as it does not rise significantly above this level.)
Oil level	Is the oil level decreasing ? (Check the oil level with a dipstick or visible oil gauge when the reducer is not operating)
Oil leakage	Is oil leaking from the oil seal or other sections?
Foundation bolt	Have any bolts come loose ?
Chain and belt	Have any transmission belts or chains come loose ?

When any abnormality is found during daily inspection, take appropriate corrective measures based on "9. Troubleshooting (P. 10)"

If normal operation is still not possible, contact the nearest agent, distributor, or service office.

8 — 2) Change of lubricant

Oil filling	Change time		Usage conditions
	At purchasing		
	1st time	Sooner time of either after 500hrs operation or half of a year	-
Oil change	2nd time	Sooner time of either after 2,500hrs operation or half of a year	-
	3rd time or later	Sooner time of either every 5,000hrs or each year	In the case oil temperature is lower than 70°C
		Sooner time of either every 2,500hrs or half of a year	In the case oil temperature is 70°C or higher

Deterioration of the oil will be accelerated when the ambient temperature changes rapidly or the ambient atmosphere contains corrosive gases. In these situations consult with the lubricant manufacturer.

8 — 3) Lubricant cooler (Special specification)

- Periodically inspect and clean the cooling coil and water cooling unit. The periodical inspection cycle depends on the degree of oil contamination and the quality of cooling water. However, be sure to conduct inspection and cleaning every 3 — 6 months.

- Unless water quality control is sufficient, water leakage may occur although inspection and cleaning are conducted periodically.

- The quality of cooling water should conform to JRA9001 (The Japan refrigeration and air conditioning industry association).

Standard values are shown in the table below for reference.

(1) maintenance of cooling coil

- When the reducer will not be used for an extended period of time, remove the cooling water. Cooling water remaining in the pipe will cause corrosion. The same applies to cases where the reducer operation is stopped in places where cooling water will be frozen in winter.

(2) Maintenance of water cooling unit

- Remove the hood on the U — turn side to check the water cooling unit for contamination. Remove the oil from the drain plug of the cooling unit to check the condition of the oil side. Check the anticorrosion zinc bar at that time, and replace it with a new one when it is reduced by half or less. It should be changed in 3 — 6 months depending on the water quality.

- When the reducer is to be operated in places where cooling water is frozen in winter, remove cooling water every day.

pH	(25°C)	6.5 — 8.0	Sulfate ion	(PPM)	200 or less
Electric conductivity	(25°C $\mu\text{s/cm}$)	800 or less	Total ion	(PPM)	1.0 or less
M alkalinity	(PPM)	100 or less	Ammonium ion	(PPM)	1.0 or less
Total hardness	(PPM)	200 or less	Sulfur ion	(PPM)	Not detected
Chlorine ion	(PPM)	200 or less	Silica	(PPM)	50 or less

(PPM = mg / liter)

(The Japan refrigeration and air conditioning industry association)

9. Troubleshooting

When any abnormality occurs in the reducer, refer to the following table and take appropriate measures as soon as possible. If they are not repairable, contact the nearest agent, distributor or service office.

Table 7

Details of trouble		Cause	Correction
The input shaft rotates, but the output shaft will not.		Damage due to overloaded gears or shafts	Repair at a specialized workshop
The output shaft turns when there is no load. But it seizes up when a load is applied. Reverse rotation is possible.		The key is out of position	Place the key in position
		Scorched bearing	Repair at a specialized workshop
		Poor adjustment of protective device	Adjust the protective device
		Incorrect wiring for the motor	Change the connection
Excessive temperature rise		Overload	Reduce the load to the specified value
		Scorched bearing	Repair at a specialized workshop
		The ambient temperature is too high	Improve the ventilation method
		Damage due to overload applied to gears, bearings, etc.	Repair at a specialized workshop
Oil leakage	Oil leaks from the input / output shaft sections,	Damaged oil seal	Change the oil seal
	Oil leaks from the joint surface of the housing.	Scratches or abrasion of the lip contact section	Repair at a specialized workshop
		Loose tightening bolt	Tighten the tightening bolts to the proper torque
Abnormal sound. Excessively high vibration.		Damaged gears, shafts, or bearings	Repair at a specialized workshop
		Deformation of the housing due to irregular installation surface	Flatten the installation surface or use liners for adjustment
		Resonance due to insufficient rigidity of installation base	Reinforce the installation base to improve the rigidity
		Incorrect alignment with the mating machine	Align the shaft center
		Transmission of the vibration of the mating machine to the reducer	Independently operate the reducer to check the source of abnormal sound

10. Disassembly / reassembly and disposal

10 — 1) Disassembly and reassembly

▲ CAUTION

- Repair, disassembly, and reassembly should be handled by properly trained technicians ; otherwise, the system may be damaged.

10 — 2) Disposal

▲ CAUTION

- Dispose the reducer and lubricant as general industrial waste.

11. Construction drawing

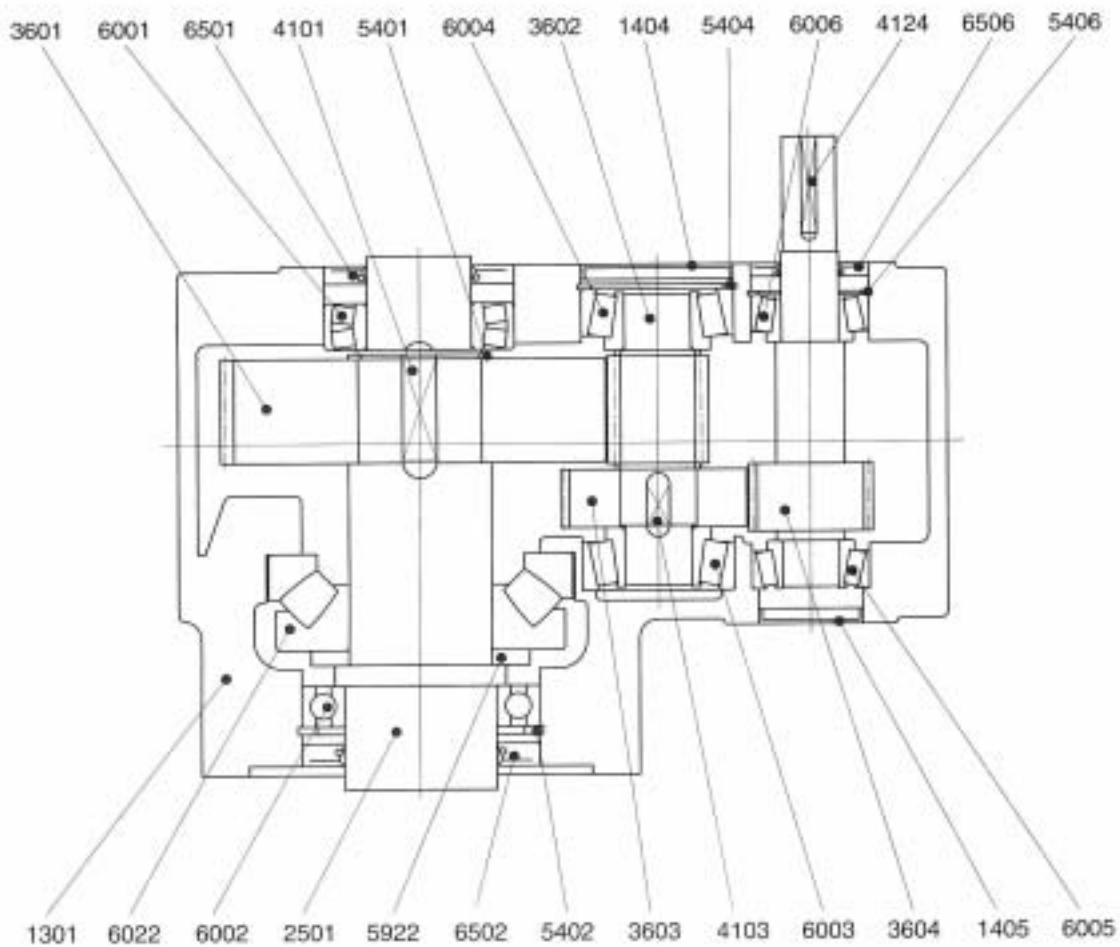

Fig. 6 SEC 005-030

Ref. No.	Part name	Ref. No.	Part name	Ref. No.	Part name
1301	Housing	4103	Key	6002	Deep groove ball bearing
1404	Seal cap	4124	Key	6003	Tapered roller bearing
1405	Seal cap	5401	Snap ring	6004	Tapered roller bearing
2501	Hollow shaft	5402	Snap ring	6005	Tapered roller bearing
3601	Helical gear	5404	Snap ring	6006	Tapered roller bearing
3602	Helical pinion shaft	5406	Snap ring	6501	Oil seal
3603	Helical gear	5922	Thrust ring	6502	Oil seal
3604	Helical pinion shaft	6022	Spherical thrust roller bearing	6506	Oil seal
4101	Key	6001	Spherical roller bearing		

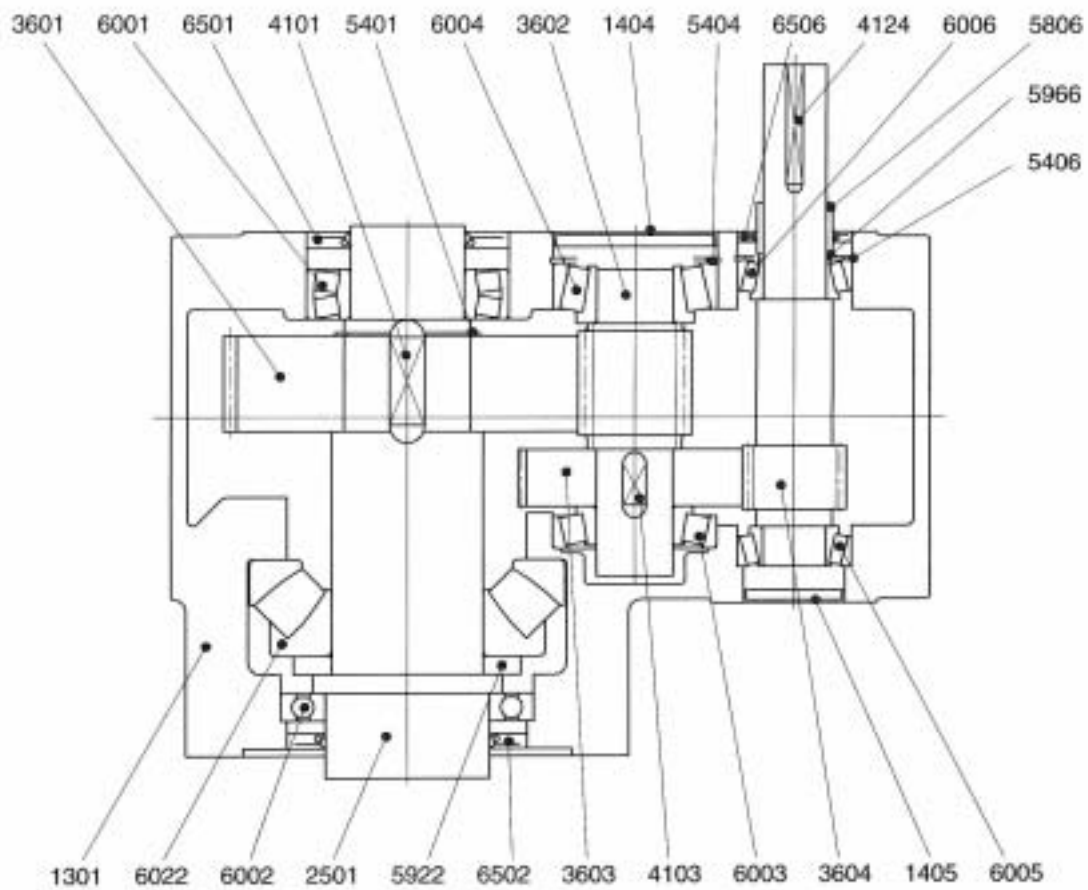

Fig. 7 SEC 040-050

Ref. No.	Part name	Ref. No.	Part name	Ref. No.	Part name
1301	Housing	4103	Key	6001	Spherical roller bearing
1404	Seal cap	4124	Key	6002	Deep groove ball bearing
1405	Seal cap	5401	Snap ring	6003	Tapered roller bearing
2501	Hollow shaft	5404	Snap ring	6004	Tapered roller bearing
3601	Helical gear	5406	Snap ring	6005	Tapered roller bearing
3602	Helical pinion shaft	5806	Collar	6006	Tapered roller bearing
3603	Helical gear	5922	Thrust ring	6501	Oil seal
3604	Helical pinion shaft	5966	Spacer	6502	Oil seal
4101	Key	6022	Spherical thrust roller bearing	6506	Oil seal

12. Locations of oil filler and drain plug

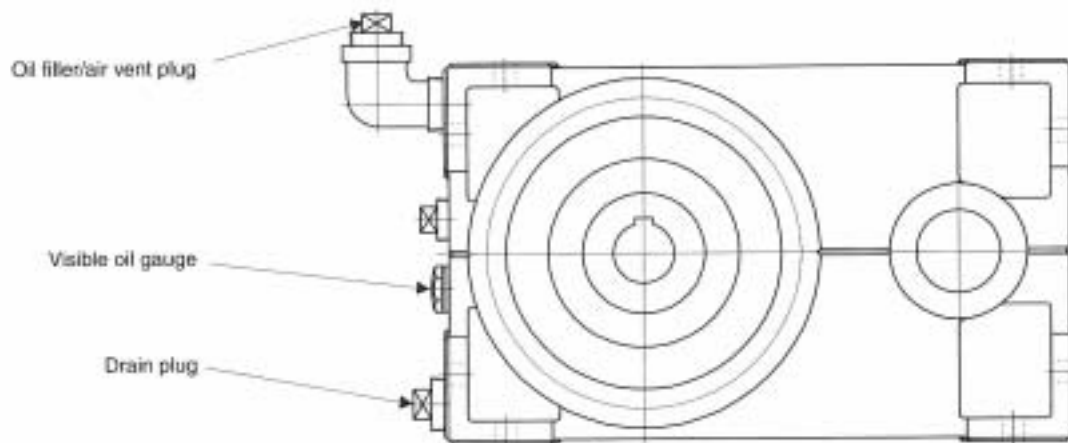

Fig. 8 Horizontal

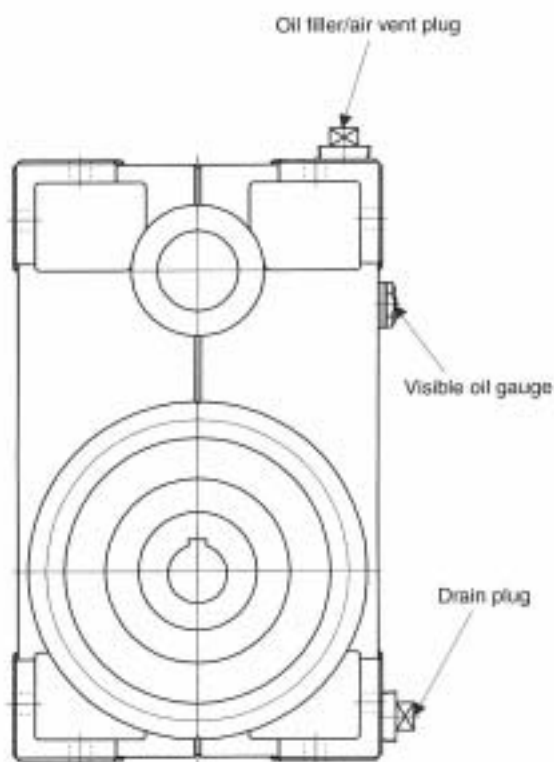

Fig. 9 Upright (HSS is in the upper side)

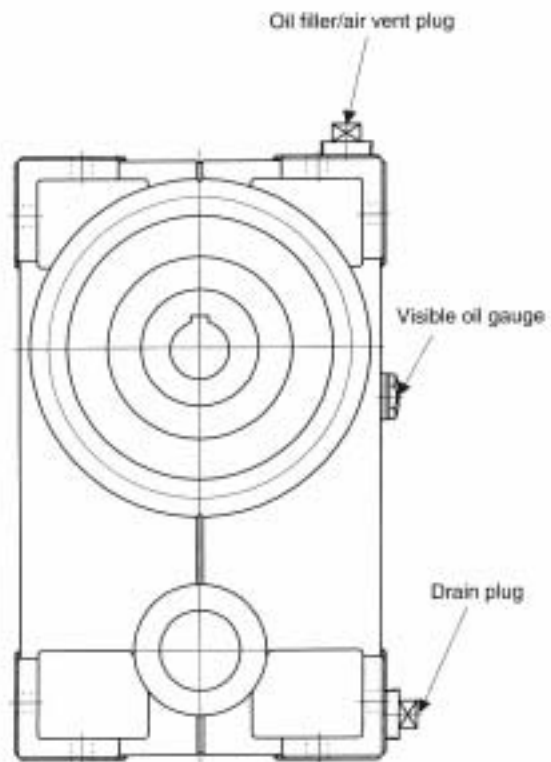

Fig. 10 Upright (HSS is in the lower side)

13. Warranty

The scope of our warranty for our products is limited to the range of our manufacture.
Warranty (period and contents)

Warranty Period	The warranty period for the Products shall be 18 months after the commencement of delivery or 18 months after the shipment of the Products from the seller's works or 12 months from the Products coming into operation, whichever comes first.
Warranty Condition	In case any problems, troubles or damages on the Products arise due to defects in the Products during the above "Warranty Period", although the Products are appropriately and properly installed in, connected or combined to the equipment or machines, or maintained in accordance with the maintenance manual and are properly operated under the conditions as described in the catalogue or otherwise as agreed upon in writing between the Seller and the Buyer or its customers, the Seller will Provide, at its sole discretion, appropriate repair or replacement on the Products free of charge, except as stipulated in the "Exception for Warranty" as described below. However, in the event that the Products is installed in, connected or combined to or integrated into the equipment or machines, the Seller shall not reimburse the costs for removal or re-installation of the Products or other incidental costs related thereto and any lost opportunity, loss of profit or any other incidental or consequential losses or damages incurred by the Buyer or its customers.
Exception for Warranty	Notwithstanding the above warranty, the warranty as set forth herein shall not be applied to the problems, troubles or damages on the Products which are caused by: 1. installations, connections, combinations or integration of the Products in or to other equipment or machines, which are supplied by any person or entity other than the Seller, 2. insufficient maintenance or improper operation by the Buyer or its customers, such that the Product is not appropriately maintained in accordance with the maintenance manual provided or designated by the Seller, 3. improper use or operation of the Products by the Buyer or its customers which are not informed to the Seller, including, without limitation, the Buyer's or its customers' operation of the Products not in conformity with the specifications, or use of the lubrication oil in the Products which is not recommended by the Seller, 4. troubles, problems or damages on any equipment or machines in or to which the Products are installed, connected or combined or installed, or any specifications particular to the Buyer or its customers, or 5. any changes, modifications, improvements or alterations on the Products or those functions which are rendered on the Products by any person or entity other than the Seller, 6. any parts in the Products which are supplied or designated by the Buyer or its customers, 7. earthquake, fire, flood, sea-breeze, gas, thunder, acts of God or any other reasons beyond the control of the Seller, 8. waste, exhaustion, normal wear and tear, or deterioration on the parts of the Products, such as bearing, oil-seal, 9. any other troubles, problems or damages on the Products which are not attributable to the Seller.

Worldwide Sumitomo Network

U.S.A.

Sumitomo Machinery Corporation of America
4200 Holland Blvd.,
Chesapeake, VA 23323
Tel: (1)757-485-3355
Fax: (1)757-487-3193

Canada

SM-Cyclo of Canada, Ltd.
870 Equestrian Court Oakville,
Ontario, Canada L6L 6L7
Tel: (1)905-469-1050
Fax: (1)905-469-1055

Mexico

SM-Cyclo De Mexico, S.A. de C.V.
Calle "C" No. 506A Parque Industrial
Almacentro Apodaca, N. L., Mexico 66600
Tel: (52)81-8369-3697
Fax: (52)81-8369-3699

Brazil

SM-Cyclo Redutores Do Brasil Ltda.
Av. Fagundes Filho, 191 Metro Sao Judas
Edificio Houston-Sala H123 Sao Paulo-SP
Brazil 04304-010
Tel: (55)11-5585-3600
Fax: (55)11-5585-9990

Chile

SM-Cyclo De Chile, Ltda.
San Pablo Ave, 3507 Quinta Normal,
Santiago, Chile
Tel: (56)2-786-6963
Fax: (56)2-786-6964

Argentina

SM-Cyclo De Argentina S.A.
Montes de Oca #6719, (B1606BMG) Munro,
Buenos Aires, Argentina
Tel: (54)11-4765-5288
Fax: (54)11-4765-5517

United Kingdom

Sumitomo (SHI) Cyclo Drive Europe, Ltd.
Marfleet Kingston upon Hull HU9 5RA,
United Kingdom
Tel: (44)1482-788022
Fax: (44)1482-713205

SM-Cyclo U.K. Ltd.

Marfleet Kingston Upon Hull HU9 5RA,
United Kingdom
Tel: (44)1482-790340
Fax: (44)1482-790321

France

SM-Cyclo France E.U.R.L.
65/75 Avenue Jean Mermoz
F-93126 La Courneuve France
Tel: (33)149-929494
Fax: (33)149-929490

Italy

SM-Cyclo Italy Srl.
Via dell' Artigianato 231-20010
Cornaredo (Mi), Italy
Tel: (39)02-9356-2121
Fax: (39)02-9356-9893

Netherlands

SM-Cyclo Benelux BV
Den Engelsman 16D NL-6026 RB
Maarheeze The Netherlands
Tel: (31)495599777
Fax: (31)495593177

Sweden

SM-Cyclo Scandinavia AB
Företagsvägen 30A S-232 37
Arlöv Sweden
Tel: (46)40430220
Fax: (46)40431001

Spain

SM-Cyclo Iberia, S.L.
C/Landabari N°4 Escalera 1, 2°izqda Leioa
48940 Vizcaya Spain
Tel: (34)944-805 389
Fax: (34)944-801 550

Germany

Sumitomo (SHI) Cyclo Drive Germany, GmbH
Cyclostraße 92
D-85229 Markt Indersdorf
Tel: (49)8136-66-0
Fax: (49)8136-5771

Austria

SCG Branch Austria Office
Gruentaler Straße, 30a A-4028 Linz, Austria
Tel: (43)732-330 958
Fax: (43)732-331 978

China

Sumitomo (SHI) Cyclo Drive China, Ltd.
26F, Raffles City, No.268 Xizang
Road Central, Shanghai, 200001 China
Tel: (86)21-6340-4000
Fax: (86)21-6340-3673

Hong Kong

SM-Cyclo of Hong Kong Co., Ltd.
Unit 1802, 18/F., Park Building, 476
Castle Peak Road, Kowloon, Hong Kong
Tel: (852)3529-2093
Fax: (852)2460-1882

Singapore

Sumitomo (SHI) Cyclo Drive
Asia Pacific Pte. Ltd.
No.36 Tuas South Street 3,
Singapore 638031
Tel: (65)6863-2238
Fax: (65)6863-4238

Malaysia

SM-Cyclo of Malaysia Sdn. Bhd.
NO.2, Jalan BP 4/1,
Bandar Bukit Puchong, 47100 Puchong,
Selangor Darul Ehsan, Malaysia.
Tel: (60)3-80612909
Fax: (60)3-80613909

Thailand

SM-Cyclo of Thailand Co., Ltd.
195, Empire Tower
Unit 1504, 15th Floor
South Sathorn Road, Yannawa Sathorn
Bangkok 10120, Thailand
Tel: (66)2-670-0998
Fax: (66)2-670-0999

Vietnam

Representative Office
4th Floor, 99 Nguyen Thi Minh Khai St.
Ward Ben Thanh, District 1, HCM City, Vietnam
Tel: (84)8-925-6504
Fax: (84)8-925-6505

Australia

SM-Cyclo of Australia Pty., Ltd.
9 Holbech Rd., Arndell Park, NSW, 2148
Tel: (61)2-8811-6555
Fax: (61)2-8811-6500

Philippines

Representative Office
Unit 23E Burgundy Corporate Tower
252 Sen. Gil Puyat Ave. Makati City
Tel: (63)2-888-5866
Fax: (63)2-843-0021

India

SCA Liaison Office
759/17, Ramkripa Apartment, Flat No.2,
First Floor Capt. A. Ranade Path,
Deccan Gymkhana, Pune 411004,
Maharashtra, India
Tel: (91)20-2565-3760
Fax: (91)20-2565-3755

Taiwan

Tatung SM-Cyclo Co., Ltd.
22 Chungshan N. Road.,
3rd Sec. Taipei,
Taiwan, 104 R.O.C.
Tel: (886)2-8676-1382
Fax: (886)2-8676-2285

Korea

SM-Cyclo of Korea Co., Ltd.
Royal Bldg, 9F Rm. 913,
5 Dangju-dong Chongro-ku,
Seoul, Korea 110-721
Tel: (82)2-730-0151
Fax: (82)2-730-0156

Japan

Sumitomo Heavy Industries, Ltd.
9-11, Kitashinagawa 5-Chome Shinagawa-Ku,
Tokyo 141-8686, Japan
Tel: (81)3-5488-8363
Fax: (81)3-5488-8365

 **Sumitomo Heavy Industries, Ltd.**

POWER TRANSMISSION & CONTROLS GROUP

5-9-11, KITA-SHINAGAWA SHINAGAWA-KU, TOKYO 141-8686, JAPAN
PHONE: (03)5488-8363 FAX: (03)5488-8365